

C 330/630-... ECO

FLOOR STANDING GAS CONDENSING BOILERS

■ C 330-280 to 650 ECO: from 56 to 651 kW, gas condensing boilers simple body, for hot water central heating and DHW production with independent calorifier

■ C 630-560 to 1300 ECO: from 74 to 1303 kW, gas condensing boilers double body, for hot water central heating and DHW production with independent calorifier



C 330-... ECO



C 630-... ECO



Heating and DHW production with independent calorifier



Condensing



All natural gases



CE identification No.: 0063CL3613

All of these boilers are fitted as standard with a DIEMATIC iSystem or IniControl control panel.

The DIEMATIC iSystem and options, enable: control of complex installations, integration into existing systems, control and regulation of a domestic hot water circuit as well as a circuit with a mixing valve. For larger installations, it is possible to connect 2 to 10 boilers of type C330-... ECO or 5 boilers of type C 630-... ECO in a cascade configuration. The DIEMATIC iSystem control panel is fitted to the master boiler and the IniControl is fitted to the secondary boilers.

Various air/flue gas connection configurations are possible. We offer two types of solution: by vertical forced flue or to a chimney (see page 19).

■ OPERATING CONDITIONS

Max. operating temperature: 90°C

Safety thermostat: 110°C

Max. operating pressure: 7 bar

Min. operating pressure: 0,8 bar

Power supply: 230 V/50 Hz

■ HOMOLOGATION

C 330-... ECO: B₂₃ - B_{23P} - C₃₃ - C₅₃ - C₆₃ - C₈₃ - C₉₃

C 630-... ECO: B₂₃ - B_{23P} - C₃₃ - C₅₃ - C₆₃ - C₈₃ - C₉₃

■ GAS CATEGORY

I_{2H}, NO_x classification: 5

PRESENTATION

C 330-... ECO and C 630-... ECO boilers are floor-standing gas condensing boilers, delivered assembled and tested in the factory.

HIGH PERFORMANCE

- Annual operating efficiency up to > 109%.
- Efficiency class ★★★★★ CE.
- Low pollutant emissions:
 - NO_x < 60 mg/kWh,
 - CO < 20 mg/kWh.
- Low noise level and electricity consumption thanks to the modulating fan:
 - Mean noise level of 61 to 65 dB (A) at a distance of 1m from the boiler,
 - 46 to 1526 W (C 630-1140) maximum depending on the output
 - NO_x classification: 5

PARTICULARITY OF C 630-... ECO

They consist of 2 x C 330-... ECO boilers with the same power, each having a control panel and assembled with a flue gas collector.



A flue gas valve integrated in the combustion line prevents any interference of the discharge of the flue gases from the line's 2 generators, thus facilitating cascade installation.

STRONG POINTS

- Exchanger in cast aluminium/silicium sections, highly resistant to corrosion, with self-cleaning properties linked to the flow of condensates requiring no minimum water flow (except when operating > 75°C) using the device for regulation of the burner modulation, which manages the transitory phases in the installation which are responsible for very low or even zero flow rates in the boiler.
- Cylindrical total remix gas burner with metallic fibre coating, modulating from 20 to 100% from C 330-... ECO and from 15 to 100% for C 630-... ECO:

- Perfect adaptation of boiler output to the actual needs of the installation,
- Optimum combustion quality over the entire power range by maintaining a constant air/gas ratio through the venturi system.
- Electronic ignition.
- Ionisation sensor.
- DIEMATIC iSystem control panel or IniControl control panel (1 panel on C 330-... ECO, 2 panels on C 630-... ECO) for which the control system is open to all installation configurations, including the most complex: cascade operation possible for 2 to 10 type C 330-... ECO boilers or 5 type C 630-... ECO boilers.
- Numerous control panel and connection configuration options, which enable the management of external safety devices, modulating pumps, systems combined with solar energy or heat pumps and the programmed control of heating circuits with mixing valves.
- It is designed to communicate with DIEMATIC VM iSystem control systems and with remote control systems compatible with the ModBus protocol.
- Optional return separation possible (2nd return to be dually controlled for C 630-... ECO) for maximum exploitation of condensation.
- Easy installation:
Boiler positioning is particularly easy thanks to the castor + rail guidance system, which can be used to slide the boiler from its pallet and move it to its final position,
Can be dismantled down to the boiler body on the frame with its castors, to access awkward locations.
- Compactness: 1,53 m² floor space and 568 kg for 651 kW.
- Boiler assembled and tested in the factory.
- Easy maintenance:
Self-cleaning condensing boiler body,
 - Rapid burner access via removable covers,
 - Rapid exchanger access via the inspection hatch.

MODELS

Boiler	Control panel	Model		Useful output range at 50/30°C (kW)	
C 330 ECO  <p>- For heating, DHW production with independent calorifier. C 330-... ECO boilers are available in 2 versions for hydraulic connection to the left or right, with DIEMATIC iSystem or IniControl control panel</p>	DIEMATIC iSystem	Hydraulic connection :			
		to the right		to the left	
		C 330-280 ECO VD DIEMATIC iSystem	C 330-280 ECO VG DIEMATIC iSystem	56 to 279	
		C 330-350 ECO VD DIEMATIC iSystem	C 330-350 ECO VG DIEMATIC iSystem	71 to 350	
		C 330-430 ECO VD DIEMATIC iSystem	C 330-430 ECO VG DIEMATIC iSystem	84 to 425	
		C 330-500 ECO VD DIEMATIC iSystem	C 330-500 ECO VG DIEMATIC iSystem	98 to 497	
	IniControl	C 330-570 ECO VD DIEMATIC iSystem	C 330-570 ECO VG DIEMATIC iSystem	113 to 574	
		C 330-650 ECO VD DIEMATIC iSystem	C 330-650 ECO VG DIEMATIC iSystem	127 to 651	
		C 330-280 ECO VD IniControl	C 330-280 ECO VG IniControl	56 to 279	
		C 330-350 ECO VD IniControl	C 330-350 ECO VG IniControl	71 to 350	
		C 330-430 ECO VD IniControl	C 330-430 ECO VG IniControl	84 to 425	
		C 330-500 ECO VD IniControl	C 330-500 ECO VG IniControl	98 to 497	
C 630 ECO  <p>- For heating, DHW production with independent calorifier. Special properties: - Composed of 2 boilers type C 330-... ECO wired in cascade, with: • DIEMATIC iSystem + one IniControl control panels or • 2 IniControl panels or • 2 DIEMATIC iSystem panels</p>	DIEMATIC iSystem + IniControl	C 630-560 ECO DIEMATIC iSystem + IniControl	C 630-560 ECO VG DIEMATIC iSystem + IniControl	74 to 558	
		C 630-700 ECO DIEMATIC iSystem + IniControl	C 630-700 ECO VG DIEMATIC iSystem + IniControl	94 to 700	
		C 630-860 ECO DIEMATIC iSystem + IniControl	C 630-860 ECO VG DIEMATIC iSystem + IniControl	131 to 850	
		C 630-1000 ECO DIEMATIC iSystem + IniControl	C 630-1000 ECO VG DIEMATIC iSystem + IniControl	130 to 994	
		C 630-1140 ECO DIEMATIC iSystem + IniControl	C 630-1140 ECO VG DIEMATIC iSystem + IniControl	156 to 1148	
		C 630-1300 ECO DIEMATIC iSystem + IniControl	C 630-1300 ECO VG DIEMATIC iSystem + IniControl	165 to 1303	
	2 x IniControl	C 630-560 ECO 2 IniControl	C 630-560 ECO VG 2 IniControl	74 to 558	
		C 630-700 ECO 2 IniControl	C 630-700 ECO VG 2 IniControl	94 to 700	
		C 630-860 ECO 2 IniControl	C 630-860 ECO VG 2 IniControl	131 to 850	
		C 630-1000 ECO 2 IniControl	C 630-1000 ECO VG 2 IniControl	130 to 994	
		C 630-1140 ECO 2 IniControl	C 630-1140 ECO VG 2 IniControl	156 to 1148	
		C 630-1300 ECO 2 IniControl	C 630-1300 ECO VG 2 IniControl	165 to 1303	
2 x DIEMATIC iSystem	C 630-560 ECO 2 DIEMATIC iSystem	C 630-560 ECO VG 2 DIEMATIC iSystem	74 to 558		
	C 630-700 ECO 2 DIEMATIC iSystem	C 630-700 ECO VG 2 DIEMATIC iSystem	94 to 700		
	C 630-860 ECO 2 DIEMATIC iSystem	C 630-860 ECO VG 2 DIEMATIC iSystem	131 to 850		
	C 630-1000 ECO 2 DIEMATIC iSystem	C 630-1000 ECO VG 2 DIEMATIC iSystem	130 to 994		
	C 630-1140 ECO 2 DIEMATIC iSystem	C 630-1140 ECO VG 2 DIEMATIC iSystem	156 to 1148		
	C 630-1300 ECO 2 DIEMATIC iSystem	C 630-1300 ECO VG 2 DIEMATIC iSystem	165 to 1303		

BOILER SPECIFICATIONS

Model	C 330-... ECO						C 630-... ECO							
	280	350	430	500	570	650	560	700	860	1000	1140	1300		
Max. nominal useful output at Pn (50/30°C)	kW	279	350	425	497	574	651	558	700	850	994	1148	1303	
Efficiency in% Pci, at load...% Pn and temp... °C	- 100% Pn at average temp. 70°C	%	98.0	98.1	98.2	98.3	98.4	98.5	98.0	98.1	98.2	98.3	98.4	98.5
	- 100% Pn at return temp. 30°C	%	104.8	105.2	105.6	106.0	106.4	106.8	104.8	105.2	105.6	106.0	106.4	106.8
	- 30% Pn at return temp. 30°C	%	109.0	109.0	108.6	108.3	107.9	107.6	109.0	109.0	108.6	108.3	107.9	107.6
Useful efficiency at 100% of rated heat output (I)	%	88.2	88.3	88.4	-	-	-	-	-	-	-	-	-	
Useful efficiency at 30% of rated heat output (I)	%	98.6	98.6	98.5	-	-	-	-	-	-	-	-	-	
Annual output (DIN 4702, section 8)	%	109.6	109.5	109.4	109.3	109.2	109.1	109.6	109.5	109.4	109.3	109.2	109.1	
Nominal water flow rate at $\Delta t = 20$ K	m ³ /h	11.3	14.2	17.0	19.9	22.7	25.9	22.5	28.9	34.1	39.7	45.4	51.8	
Aux. electrical output at Pn	W	279	334	426	543	763	723	558	668	852	1086	1526	1446	
Aux. electrical output at P mini.	W	46	46	58	61	62	55	92	92	116	122	124	110	
Nominal output mini/maxi at 80/60°C	kW	51/261	65/327	79/395	92/462	106/530	119/601	69/522	87/654	123/790	122/922	148/1060	158/1202	
Water draught at $\Delta t = 20$ K	mbar	113	110	120	110	125	130	113	110	120	110	125	130	
Gas flow rate max. (15°C - 1013 mbar)	- natural gas H	m ³ /h	28.1	35.2	42.5	49.6	57.0	64.6	56.2	70.4	85.0	99.2	114.0	129.2
	- natural gas L	m ³ /h	32.7	41.0	49.5	57.7	66.3	75.1	65.4	82.0	99.0	115.4	132.6	150.2
Mass flue gas flow rate max.	kg/h	448	560	676	789	907	1026	896	1120	1352	1578	1814	2052	
Max. flue gas temperature	°C	80	80	80	80	80	80	80	80	80	80	80	80	
Flue gas pressure available at the nozzle	Pa	130	120	130	150	150	150	130	120	130	130	130	150	
Water content	l	49	60	71	82	93	104	98	120	142	164	186	208	
Minimum water flow (*)	m ³ /h	3.4	4.2	5.1	5.9	6.8	7.8	6.8	8.4	10.2	11.8	13.6	15.6	
Stand-by losses at $\Delta t = 30$ K EN 15420	W	464	479	493	508	522	537	928	958	986	1016	1044	1074	
	%	0.17	0.14	0.12	0.11	0.10	0.09	0.17	0.14	0.12	0.11	0.1	0.09	
Floor area	m ²	1.31	1.31	1.31	1.53	1.53	1.53	2.68	2.68	2.68	3.13	3.13	3.13	
Net weight	kg	364	398	433	495	531	568	707	771	837	957	1025	1095	

(*) except when operating at $> 75^\circ\text{C}$ (I) According to commission regulation n°813/2013 from 2/08/13

DESCRIPTION

C 330-... ECO

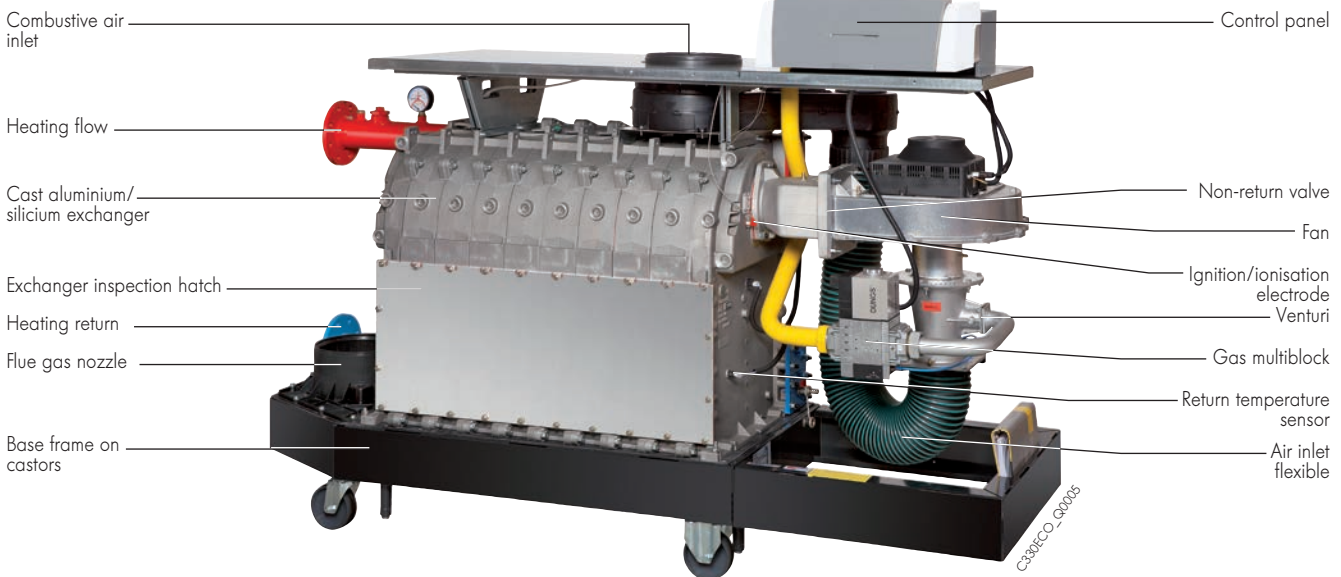

C 330-... ECO and C 630-... ECO

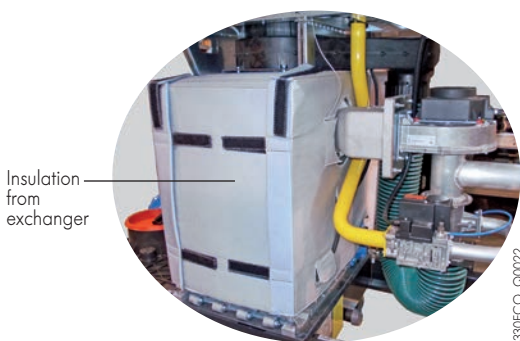

C 630-... ECO

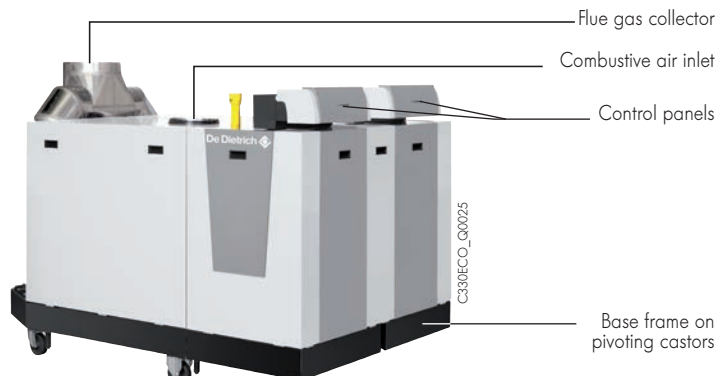

TECHNICAL SPECIFICATIONS

MAIN DIMENSIONS (IN MM AND INCHES)

C 330-... ECO - left version

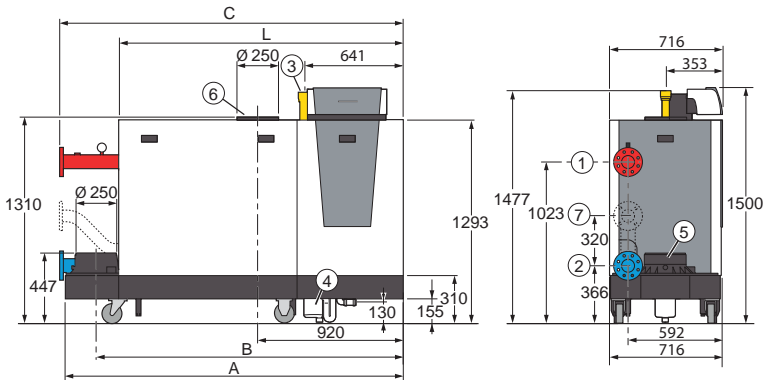

C 330-... ECO - right version

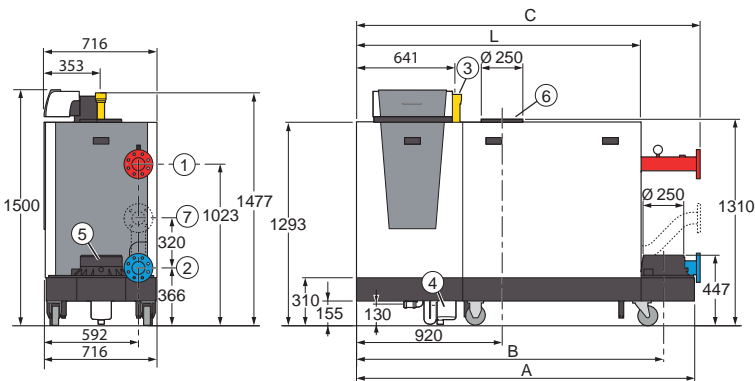

	C 330-280	C 330-350	C 330-430	C 330-500	C 330-570	C 330-650
A (mm)	1833	1833	1833	2142	2142	2142
B (mm)	1635	1635	1635	1944	1944	1944
C (mm)	1862	1862	1862	2172	2172	2172
L (mm)	1490	1490	1490	1800	1800	1800

- ① Heating flow: nozzle DN 80 (DIN 2576)
- ② Return flow: nozzle DN 80 (DIN 2576)
- ③ Gas inlet G 2" (tapped connection)
- ④ Condensates run-off, siphon provided, for PVC tube Ø 32 mm (inlet)
- ⑤ Flue gas nozzle Ø 250 mm
- ⑥ Combustive air inlet Ø 250 mm
- ⑦ Second return nozzle (optional), DN 65 (DIN 2576)

C330ECO_F0001C

C 630-... ECO

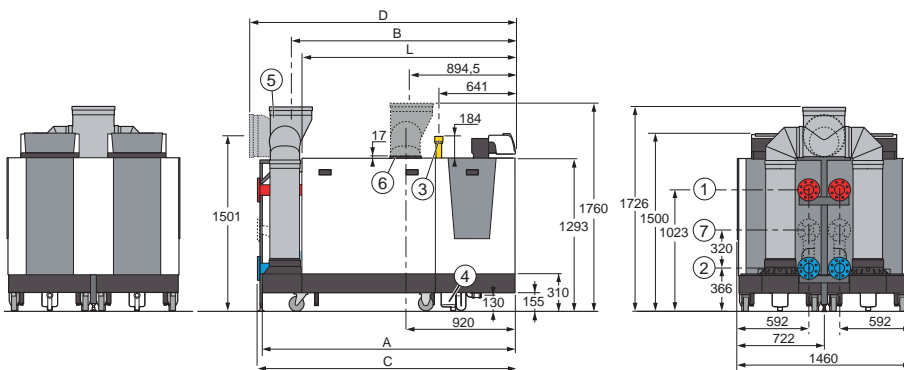

	C 630-560	C 630-700	C 630-860	C 630-1000	C 630-1140	C 630-1300
A (mm)	1833	1833	1833	2142	2142	2142
B (mm)	1635	1635	1635	1944	1944	1944
C (mm)	1862	1862	1862	2172	2172	2172
D (mm)	1962	1962	1962	2271	2271	2271
L (mm)	1490	1490	1490	1800	1800	1800

- ① Heating flow: nozzle Ø 80 (DIN 2576)
- ② Return flow: nozzle Ø 80 (DIN 2576)
- ③ Gas inlet G 2" (tapped connection)
- ④ Condensates run-off, siphon provided, for PVC tube Ø 32 mm (inlet)
- ⑤ Flue gas nozzle Ø 350 mm
- ⑥ Combustive air inlet Ø 250 mm (Air inlet collector for option Ø 350 mm)
- ⑦ Second return nozzle (optional) Ø 65 (DIN 2576)











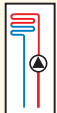

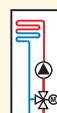

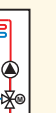







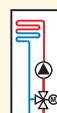

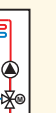



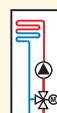

C630ECO_F0001E

Note: the control panels on the C 330/630-... ECO can be mounted in front position or laterally; see instruction delivered with the boiler.

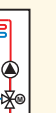
SELECTION OF THE CONTROL PANEL

The choice of the control panel will be made according to the facility to achieve.

INSTALLATION WITH 1 x C 330 ECO BOILER

2 type of control panel available	Secondary circuits that can be connected	Other accessories															
 <p>C 330 ECO IniControl</p>	<p>- for direct control of a circuit, without timer programming and without external sensor:</p>  <p>as standard</p>	<p>- ref. S103055: PCB SCU-S05* to connect external safety components</p>															
 <p>C 330 ECO DIEMATIC iSystem</p>	<p>- for control of a circuit:</p> <table border="1" data-bbox="571 808 1187 965"> <tr> <td></td> <td></td> <td></td> <td></td> <td></td> </tr> <tr> <td>direct</td> <td>with valve</td> <td>direct + 1 valve</td> <td>2 x with valve</td> <td>direct + 2 x with valve**</td> </tr> </table> <p>Options:</p> <table border="1" data-bbox="571 972 1187 1211"> <tr> <td>as standard</td> <td>1 sensor AD199 </td> <td>1 sensor AD199 </td> <td>1 sensor AD199 + 1 PCB + sensor AD249  </td> <td>1 sensor AD199 + 1 PCB + sensor AD249  </td> </tr> </table>						direct	with valve	direct + 1 valve	2 x with valve	direct + 2 x with valve**	as standard	1 sensor AD199 	1 sensor AD199 	1 sensor AD199 + 1 PCB + sensor AD249  	1 sensor AD199 + 1 PCB + sensor AD249  	<p>- ref. S103055: PCB SCU-S05* to connect external safety component</p>
																	
direct	with valve	direct + 1 valve	2 x with valve	direct + 2 x with valve**													
as standard	1 sensor AD199 	1 sensor AD199 	1 sensor AD199 + 1 PCB + sensor AD249  	1 sensor AD199 + 1 PCB + sensor AD249  													

* Additional functions are possible using these options, see next page.

** One or more DIEMATIC VM iSystem units will control the additional circuits, autonomously or through connection to the boiler control panel (2 circuits with one valve per unit).

CASCADE INSTALLATION WITH 2 UP TO 10 x C 330 ECO BOILERS (OR 1 OR SEVERAL C 630 ECO BOILERS)

Cascade of several C 330 ECO IniControl boilers or C 630 ECO IniControl boilers
(for installation with external control cabinet)

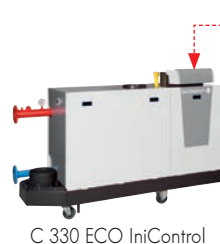
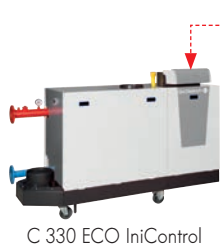

C330ECO_00001

Secondary circuits that can be connected	Obligatory accessories	Other accessories
<p>The boiler room control cabinet will manage all the installed secondary circuits.</p>	<p>All the boilers (up to 10) are connected via the PCB SCU-S05*</p> <p>Per boiler: - ref. S103055 PCB SCU-S05* to connect external safety components</p>	

* Additional functions are possible using these options, see next page.

SELECTION OF THE CONTROL PANEL

CASCADE INSTALLATION WITH 2 UP TO 10 x C 330 ECO BOILERS (OR 1 OR SEVERAL C 630 ECO BOILERS)

Cascade of boilers in which the master boiler is equipped with a DIEMATIC iSystem control panel and the secondary boilers each have an IniControl control panel (1).

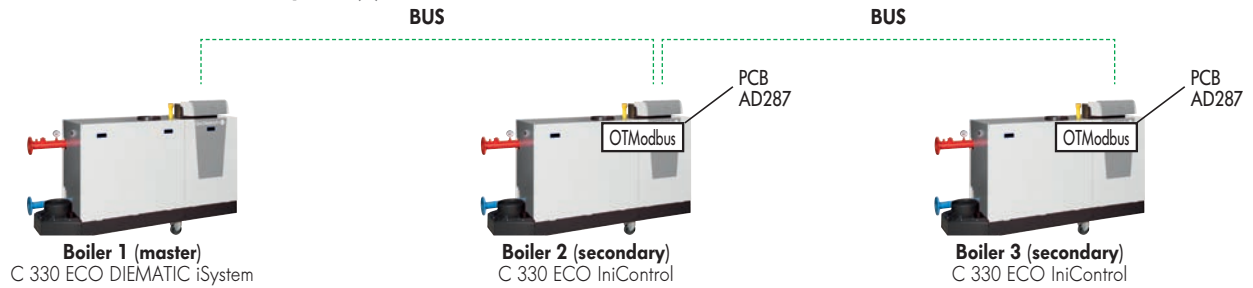

Secondary circuits that can be connected					Obligatory accessories	Other accessories
All the secondary circuits will be connected on the master boiler fitted with a DIEMATIC iSystem control panel. No additional secondary circuits can be connected to the IniControl panel (1)						
					Per secondary boiler (IniControl panel): - Package AD287: PCB OpenTherm-Modbus + BUS cable (1 PCB and a 1.5 m BUS cable is normally delivered with the C 630 boiler)	Per boiler: - ref. S103055: PCB SCU-S05* to connect external safety component
direct	with valve	direct + 1 valve	2 x with valve	direct + 2 x with valve		
Options:						
as standard	1 sensor AD199	1 sensor AD199	1 sensor AD199 + 1 PCB + sensor AD249	1 sensor AD199 + 1 PCB + sensor AD249		

* Additional functions are possible using these options, see below.

Note: do not forget to order « cascade outlet sensor », package AD250 or AD218 (1 sensor AD250 delivered with C 630 ECO iSystem).

(1) If there is a need of managing more than 1 direct and 2 x with valve it exists the possibility to replace the IniControl panel (of one or more secondary boiler(s)) by one boiler with iSystem control panel with adapted options.

ADDITIONAL FUNCTIONS

The table below indicates the additional functions available for each control panel, with various options.

Description of the additional functions	Available with optional PCB SCU-S05 (PCB is connected into the control panels)
Input 0 - 10 V, configurable (1)	X
Output 0 - 10 V, configurable:	
- return of the signal indicating the heating water temperature	X
- return of a % signal	X
- a 0 - 10 V modulating pump command	X
- PWM modulating pump command	X
ON/OFF signal delay	X
Control of an external gas valve (1)	X
Alarm (1)	X
Control of a hydraulic isolation valve: in the case of a cascade, enabling isolation of an inactive boiler to avoid heat losses	X
Control of a motorised fume isolation valve: allows an isolation valve to be closed, if necessary	X
Control of a gas pressure switch	X
Control of a water pressure switch	X
Check of the tightness of the gas train	X
Connection of an outside sensor (1)	X

(1) Functions available in series with the DIEMATIC iSystem control panel

DIEMATIC iSYSTEM CONTROL PANEL

The **DIEMATIC iSystem** is a very advanced control panel, which includes electronic programmable regulation to modulate the boiler temperature by activating the modulating burner according to the outside temperature and also to the room temperature, if a CDI D. iSystem, CDR D. iSystem interactive remote control or simplified remote control (optional) is connected.

As standard, DIEMATIC iSystem control panel is capable of automatically operating a central heating installation with a direct circuit and 1 circuit with mixing valve (the flow sensor for the mixing valve - package AD199 - must be order separately, however).

By connecting another « PCB + sensor 1 valve circuit » (option package AD249), it is therefore possible to control up to 3 circuits in total and each of this circuits can be fitted with a CDI or CDR D. iSystem remote control (optional).

Special case: C 630-... ECO

The C 630-... ECO can be equipped, if desired:

- with a DIEMATIC iSystem control panel for a boiler and an IniControl control panel on a second boiler (the two being linked by the supplied BUS cable). The system operating on the principle of a cascade.

Connection of a domestic hot water sensor makes it possible to programme and regulate a DHW circuit (package AD212 optional). This control system has been specifically developed to enable optimum management of systems **combining various heating generators** (boiler + heat pump or + solar system...). It allows the installer to set the parameters for the entire heating installation regardless of its degree of complexity.

In the context of larger installations, it is also possible to connect 2 up to 10 x C 330-ECO or 5 x C 630-... ECO boilers in cascade.

The DIEMATIC iSystem control panel will then be used as the master for the installation, the secondary boilers being fitted with the IniControl control panel. To connect more than 3 circuits possible to the master boiler make provision for a second (or further) boilers with a DIEMATIC iSystem control panel in the cascade or DIEMATIC VM iSystem wall-hung control units.

- with 2 IniControl control panels. The boiler can also be controlled through two 0-10 V signals supplied via the IF-01 interface by a control cabinet.
- with 2 DIEMATIC iSystem control panels connected in cascade. Each control panel can control one direct circuit and 2 circuits with mixing valve.

DIEMATIC iSystem CONTROL PANEL

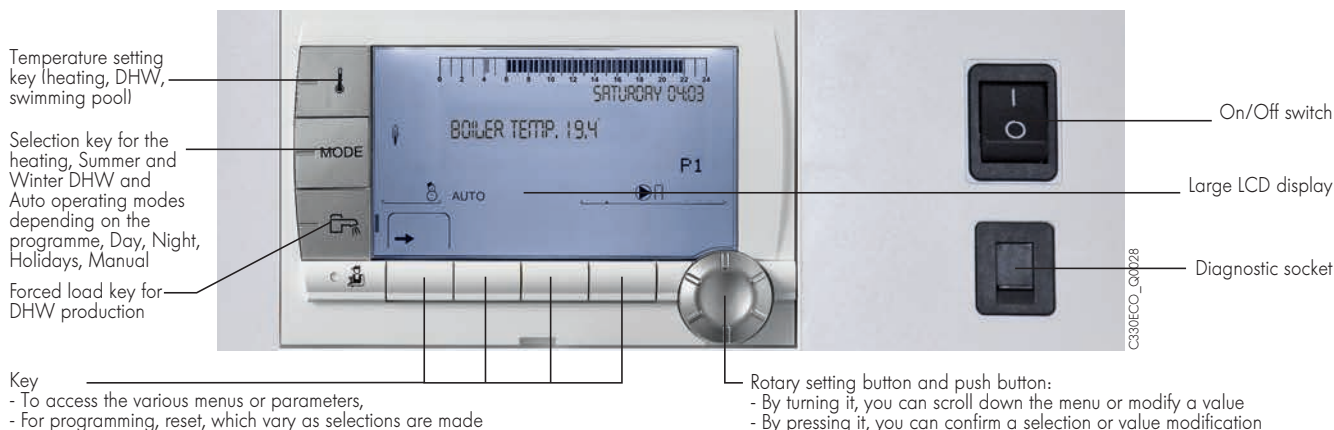

DIEMATIC iSystem CONTROL PANEL

DIEMATIC iSystem CONTROL PANEL OPTIONS



Domestic hot water sensor (length 5 m) - Package AD212

This is used for regulating the DHW temperature as a priority and programming of domestic hot water production with an independent calorifier.



Outlet sensor downstream of the valve (length 2.5 m) - Package AD199

This sensor is required to connect the first circuit with mixing valve to a boiler fitted with a DIEMATIC iSystem control panel.



PCB + sensor for 1 mixing valve (length 2.5 m) - Package AD249

This is used to control a mixing valve with an electromechanical or electrothermal motor. The PCB is inserted into the DIEMATIC iSystem panel

connected by pin connections. DIEMATIC iSystem can receive 1 "PCB + sensor" option, enabling it to control 1 additional mixing valve.

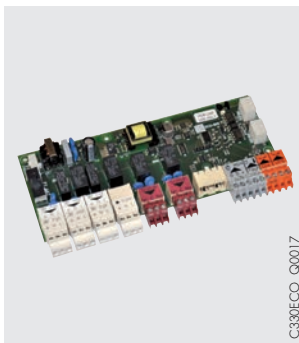

SCU-S05 PCB for connecting external safety devices - ref. S103055

This PCB can be installed in the DIEMATIC iSystem and IniControl control panels. Depending on the various components connected, it can:

- control a motorised fume isolation valve;
- control the external gas valve,
- control a hydraulic valve (isolation valve) for a cascade configuration,
- control the recycling pump

- possess a configurable analogue input 0-10 V for an outlet temperature or power modulation function,
- possess a configurable analogue output 0-10 V (indicating the heat delivered or the temperature, or used to control a pump),
- connect to a hydraulic pressure sensor,
- connect to a minimum gas pressure switch,
- connect to a tightness check,
- connect to an external temperature sensor.



Radio outside temperature sensor - Package AD251

Boiler radio module (radio transmitter) - Package AD252

The radio outside temperature sensor can be delivered as optional equipment for systems in which the installation of the external wire connection sensor delivered with DIEMATIC iSystem control panel would be too complex.

If this sensor is used:

- With a wire connection remote control (AD285 or FM52), it is necessary to order the "Boiler radio module".
- With a wireless connection remote control (AD284), it is not necessary to order a second "Boiler radio module" AD252.



CDI D. iSystem interactive remote control - Package AD285

CDR D. iSystem interactive "radio" remote control (without transmitter/receiver radio) - Package AD284

Radio boiler module DIEMATIC iSystem (transmitter/receiver) - Package AD252

These are used to override all instructions from the DIEMATIC iSystem control panel from the room in which they are installed. In addition, they enable the self-adaptability of the heating regime for the circuit concerned (one CDI D. iSystem or CDR D. iSystem per circuit).

In the case of the CDR D. iSystem, the data are transmitted by radio waves from the place where the CDR D. iSystem is installed to the transmitter/receiver box (package AD252) placed close to the boiler.



Simplified remote control with room sensor - Package FM52

This is used from the room in which it is installed to override certain instructions from the DIEMATIC iSystem panel: room temperature program and

instruction override. It is also used to enable the self-adaptability of the heating curve for the circuit concerned (1 remote control per circuit).



Room sensor - Package AD244

A room sensor is connected to activate the comfort period start-up optimization function from the room in which it is installed. It is also used to enable

the self-adaptability of the heating curve for the circuit concerned (1 sensor per circuit).

DIEMATIC iSYSTEM CONTROL PANEL

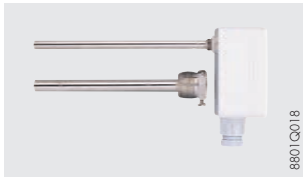

8801CQ018

Dip sensor with tube - Package AD218

This dip sensor (NTC 147) is delivered with an IP 54 junction box and a 1/2" sensor tube, length under head 120 mm. It is used instead of the

attachable sensors provided with the PCB and valve options. It can also be used on the header pipe when connecting 2 boilers in cascade.



VM_G0001

DIEMATIC VM iSystem wall-hung control unit- Package AD281

The DIEMATIC VM iSystem electronic control system, incorporated in a wall-mounted box, is used to manage and control two heating circuits and a DHW circuit and each of the heating circuits may be a direct circuit or a circuit with motorised 3-way mixing valve.

It is possible to interlink up to 20 DIEMATIC VM iSystem control systems and thus configure numerous combinations, regardless of the type of installation:

- DIEMATIC VM iSystem can be used in combination with an existing generator to control additional heating and DHW circuits. In this case, it will communicate with the generator via a BUS cable (e.g. De Dietrich boiler fitted with a DIEMATIC control panel).
- DIEMATIC VM iSystem can also be used fully autonomously on its own to control heating and DHW circuits according to the outside

temperature (sensor to be ordered separately - package FM46) independently of the generator. In addition, DIEMATIC VM iSystem can control a boiler via OpenTherm (outlet available on DIEMATIC VM iSystem) for a boiler equipped with an OpenTherm bus, or as « ON/OFF » via the auxiliary contact for any other generator (burner, HP, wood-fired boiler...).

It can also control a boiler cascade:

- Equipped with a DIEMATIC control panel
 - Equipped with an OpenTherm BUS via an interface board (1 board per generator);
- DIEMATIC VM iSystem is also equipped with an auxiliary outlet which, apart from the controlling a generator in ON/OFF mode, allows control of a heating pump, a primary pump, a second DHW circuit, an alarm signal, etc. It also has a 0-10V inlet that can be configured for ON/OFF telephone control.

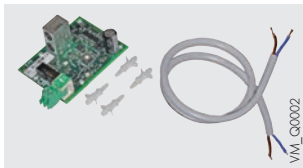

VM_G0002

OpenTherm/Modbus Interface - Package AD287

Required to control a cascade of boilers by ensuring communication between the boilers and assigning a number to each of them.

The PCB is installed directly in the IniControl control panel of the boiler.



MCA_G0012

Sensor for storage tank or sensor for cascade outlet (length 5 m) - Package AD250

Includes a sensor for managing a storage tank with a boiler, fitted with a DIEMATIC iSystem control panel.

It is also used as the flow sensor common to the cascade in the case of a cascade installation and

is delivered as standard with the C 630-... ECO to enable the 2 boilers it comprises to operate in cascade.



8227CQ020

BUS connection cable (length 12 m) - Package AD134

The BUS cable provides the connection between 2 (and up to 10 x C 330-... ECO or 5 x C 630-... ECO) boilers fitted with a DIEMATIC iSystem control panel as part of a cascade installation, as well as the connection of a wall-mounted DIEMATIC VM iSystem control panel or a transmitter from the remote management network.

A BUS cable is delivered as standard with the C 630-... ECO for the connection between a boiler equipped with an iSystem control panel and an IniControl control panel.



8199CQ043

Connection cable (length 40 m) - Package DB119

This armoured cable is intended to replace the BUS cable delivered with the C 630-... ECO (length 1.5 m) or the 12 m BUS cable (package

AD134) described above, when these turn out to be too short.

IniCONTROL CONTROL PANEL

The IniControl control panel is used to manage a direct circuit and DHW production (without programming). Burner modulation according to the outside temperature is activated by connecting the outside temperature sensor (package FM46 – to be ordered separately).

The display of the boiler temperature, the pressure in the heating network, and the operating status of the generator using symbols and alphanumeric codes is handled by the large display, which also incorporates a flashing alarm function.

To monitor the installation, optional readout of error history and hour run meters. The IniControl control panel also enables boiler management through a configurable 0-10V signal. In the case of a cascade installation, the IniControl panel will be fitted to the secondary boilers linked in series to the master boiler fitted with the DIEMATIC iSystem control panel using the BUS cable (optional).

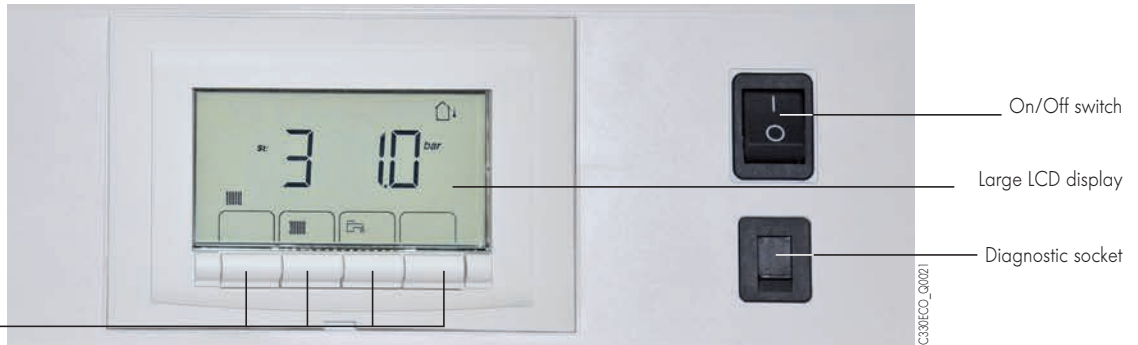

Key:
 - to access the various menus or parameters,
 - Setting and manual reset, which vary as selections are made

IniControl CONTROL PANEL OPTIONS

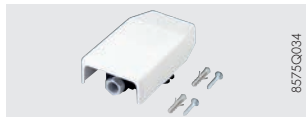

Outside sensor - Package FM46

Allows the management of the circuit heating by measuring of the outside temperature.



Programmable room thermostat (wireless) - Package AD200 Non-programmable room thermostat (wire) - Package AD140

The programmable thermostats handle the control and weekly programming of the heating by activating the burner in accordance with the various operating modes: "Automatic" according

to the program, "Permanent" at a set temperature or "Holidays". The « wireless » version is delivered with a receiver box to be affixed to the wall close to the boiler.

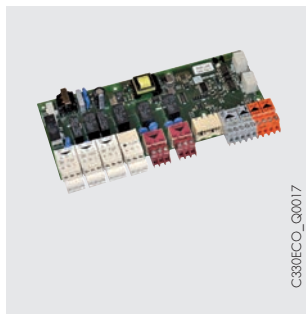

SCU-S05 PCB for connecting external safety devices - ref. S103055

This PCB can be installed in the DIEMATIC iSystem and IniControl control panels. Depending on the various components connected, it can:

- control a valve for burnt gases,
- control the external gas valve,
- control a hydraulic valve (isolation valve) for a cascade configuration,
- control the recycling pump

- possess a configurable analogue input 0-10 V for an outlet-temperature or power modulation function,
- possess a configurable analogue output 0-10 V (indicating the heat delivered or the temperature, or used to control a pump),
- connect to a hydraulic pressure sensor,
- connect to a minimum gas pressure switch,
- connect to a tightness check,
- connect to an external temperature sensor.

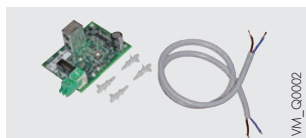

OpenTherm/Modbus Interface - Package AD287*

Required to control a cascade of boilers by ensuring communication between the boilers through assignment of a number to each of them.

The PCB is to be installed directly in the boiler's control panel.



Inter-module connecting cable (length 1.5 m) - Package AD124*

This is used for the interconnection of two DIEMATIC VM iSystem wall-mounted control systems.

*These 2 components are delivered as standard with a C630 ECO boiler fitted with a DIEMATIC iSystem control panel and an IniControl control panel.

BOILERS OPTIONS



C330ECO_Q0009

2nd return nozzle: option prefitted on delivery, to be specified on order

for C 330-280 ECO and C 630-560 ECO - ref. S101776 (1)
 for C 330-350 ECO and C 630-700 ECO - ref. S101777 (1)
 for C 330-430 ECO and C 630-860 ECO - ref. S101778 (1)
 for C 330-500 ECO and C 630-1000 ECO - ref. S101779 (1)
 for C 330-570 ECO and C 630-1140 ECO - ref. S101780 (1)
 for C 330-650 ECO and C 630-1300 ECO - ref. S101781 (1)

These packages are used to differentiate the low and high temperature return circuits and thus to

exploit condensation to the full. They include a 2nd return pipe and a water distribution pipe.

(1) order two for C 630-... ECO



C310_Q0008

Tightness checker for the Honeywell gas train, for 5 to 9 elements - ref. S103305 (1)

Tightness checker for the Dungs gas train, for 10 elements - ref. S101724 (1)

It is adapted to the gas train and checks the tightness of the safety valves during the pre-sweep. If a leak is detected, the boiler goes into safety

shutdown and the fault will be signalled by the DIEMATIC iSystem control panel.

(1) order two for C 630-... ECO



C330_Q0014

Minimum gas pressure switch for the Honeywell gas train, for 5 to 9 elements - ref. S103306 (1)

Minimum gas pressure switch for the Dungs gas train, for 10 elements - ref. S101805 (1)

It is adapted to the gas train and in case of lack supply pressure it puts the boiler into safety

shutdown and the fault will be signalled by the DIEMATIC iSystem control panel.

(1) order two for C 630-... ECO



C230_Q0002

300 mbar pressure regulator

It is fitted to the gas inlet circuit. It is necessary if the gas mains supply is at 300 mbar.

Package	model	Max. natural gas flow rate in m ³ /h	Max. output power in kW	Ø of connection
SA12	GDJ 20	24	240	Rp 3/4"
AD245	GDJ 25	70	700	Rp 1"
AD246	GDJ 50	140	1400	Rp 2"

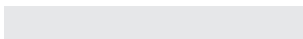

Flue gas sensor - ref. S103023



C330ECO_Q0006

Low water pressure switch - ref. S101784 (1)

(1) order two for C 630-... ECO

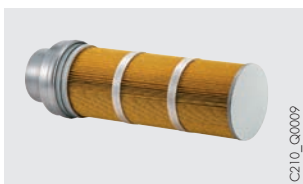

C210_Q0009

Air intake filter - Package GS20 (1)

It is fitted to the combustive air inlet and obviates a fall in output if the pre-mix gas burner is clogged owing to it being in a dusty atmosphere.

(1) order two for C 630-... ECO



C210_Q0016

Clearing knife - Package GS21

It allows the exchanger to be cleaned, which is accessed via the inspection trap in the body.



C330ECO_Q0008

4 to 8 hole adaptor flange for a pump - ref. S101775

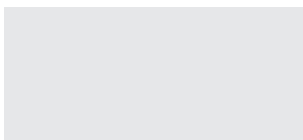

Counter flange flow/return - ref. 7606977

Counter flange 2nd return - ref. 7606978

Delivered with screws and gaskets.

BOILERS OPTIONS



Condensates neutralization system with lift pump:

- Package SA4: for C 330-280 (boilers up to 300 kW)
- Package DU15: for C 330-350 to 650 and C 630-560 to 1300)

Condensates neutralization system without lift pump:

- Package SA3: for C 330-280 to 430 (boilers up to 450 kW)
- ref. 762256: for C 330-500 to 650 and C 630-560 to 1300 (boilers up to 1300 kW) – delivered in 3 packages: 1x SA9 + 2x SA7

Neutralization granules for station - Package SA7 (25 kg)

Neutralization granules for station - ref. 94225601 (10 kg – to order at the spare parts department)

The condensates neutralization systems - packages SA4 and SA3 - are delivered with 25 kg neutralization granules, the condensates neutralization system

ref. 762256 is delivered with 2 loads of 25 kg and the neutralization system – package DU15 - with a 10 kg load ; they all delivered with their

hydraulic and electrical connection accessories to fit easily on our boilers.

Principle: The acidic condensates flow through a container filled with granules before being sent into the waste water network. An annual check of the system and particularly the effectiveness of granules by measuring the pH is necessary; where applicable it is necessary to replace the granules.

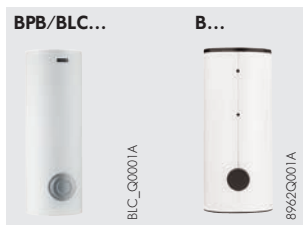

DHW production

De Dietrich B... series independent DHW tanks with a capacity of 650 to 3000 litres can be used for domestic hot water production for individual and collective residences as well as for industrial and commercial premises. They are lined with food quality standard high quartz content vitrified

enamel and protected by a magnesium anode. The specifications and performances of these tanks are given in the product catalogue and the technical leaflets.

FLUE SYSTEM OPTIONS

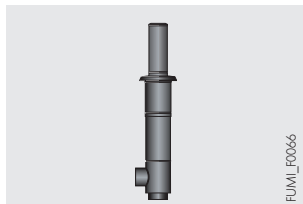

Vertical air/flue gas vent Ø 200/300 mm - ref. 51202

Vertical air/flue gas vent Ø 250/350 mm - ref. 51203

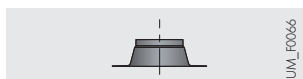

Flashing for flat roof Ø 300 mm - ref. 46157

Flashing for flat roof Ø 350 mm - ref. 46158

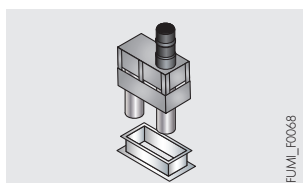

Vertical forced flue 2 x Ø 350 mm - ref. 54443



Connection adapter C 310 ECO to C 330 ECO - ref. S103178



Adapter, Ø 250 mm to Ø 200 mm - ref. S103179



Flue connection kit for 2 x C 330 ECO - ref. S103118



Air input collector for C 630 ECO- ref. S103128

HYDRAULIC MODULES FOR C 630 ECO

HYDRAULIC MODULES FOR C 630 ECO

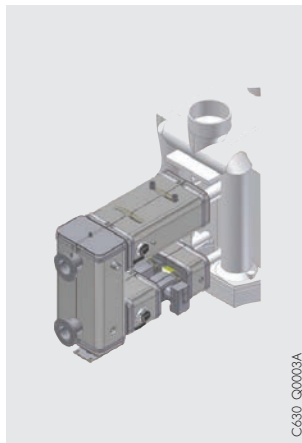

C630_Q0003A

Complete hydraulic set « DuoConnect » :

- for C 630-560 - ref. 7622302
- for C 630-700 - ref. 7622304
- for C 630-860 - ref. 7622306

The connection sets are composed by:

- 2 stainless steel compensators on flow connections
- 2 intermediate piping with flanges and free connection R1 1/2" for the safety valve
- 2 intermediate connections with flanges safety kit equipped with 2 Max. pressure switches, 1 Min pressure switch and 1 STB
- 4 valves on flow and return connections
- 1 decoupling low loss header with adjustable foot, 1/2" reservation for the system sensor,

- for C 630-1000 - ref. 7622307
- for C 630-1140 and 1300 - ref. 7622308

- 1/2" connection for air vent, R 1" connection for expansion vessel, R 1 1/2" rain away, R 2" connection for an additional generator, Rp 1 1/4" for magnetic bar (available optional)
 - 2 kits of return connections
 - 2 modulating pumps managed by 0-10V of the boiler control panel (option: PCB SCU - S05)
 - Insulation in PEE shells covered with an aluminium sheet and fast bindings
- The delivery includes all screws and gaskets



C630_Q00005

Complete safety kit for set « DuoConnect » - ref. 100016229

Equipped with:

- 2 max. pressure switches,
- 1 min. pressure switch,
- 1 additional safety thermostat.

To be ordered in duplicate for C630 ECO

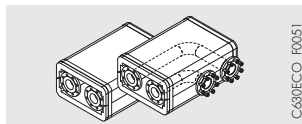

C630ECO_F0051

Kit with insulated flow/return elbows DN 80 for hydraulic set - ref. 7613414

These elbows allow the connection of the «DuoConnect» sets on the left or on the right of the C630 ECO boiler.



C630ECO_Q00003

Magnet filter cartridge- ref. 7613415

Cartridge to mounted into the disconnecting cylinder of the «DuoConnect» sets for sludge collect.

MAIN DIMENSIONS OF THE BOILERS + HYDRAULIC MODULES « DuoConnect »

Direct connection

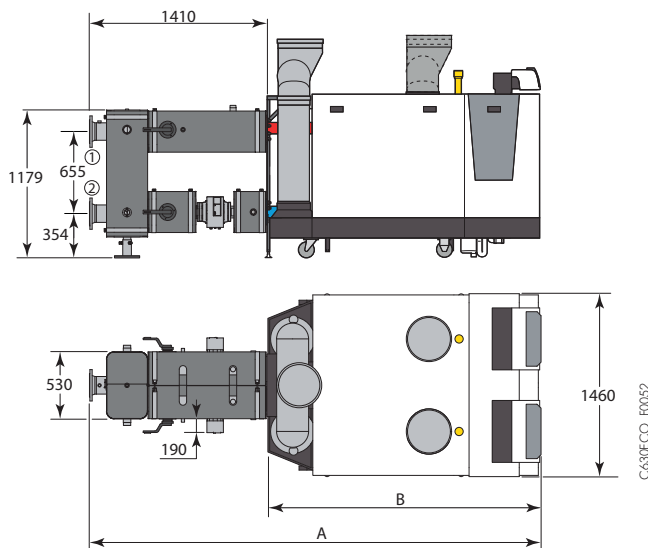

C630ECO_F0052

Side connection with insulated flow/return elbows (ref. 7613414)

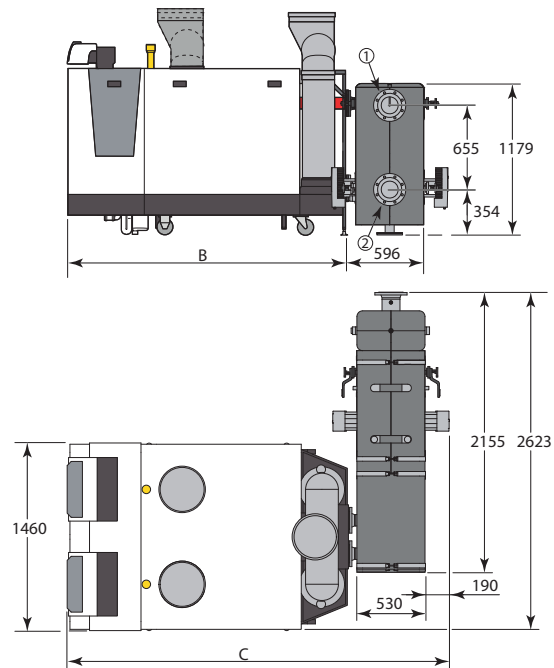

C630ECO_F0053

	A	B	C
C 630-560 to 860	3 272	1 862	2 648
C 630-1000 to 1300	2 582	2 172	2 958

① Heating flow Ø DN 25/PN 16

② Heating return Ø DN 25/PN 16

INFORMATION REQUIRED FOR INSTALLATION

STATUTORY INSTRUCTIONS ON INSTALLATION AND MAINTENANCE

The installation and maintenance of the appliance must be carried out by a qualified professional in compliance with the statutory texts of the codes of practice in force.

INSTALLATION IN BOILER ROOM

C 330/630-... ECO boilers are fitted with a castor + rail guidance system allowing them to be easily put into position: it is sufficient to roll the boiler from the pallet to its desired position

The dimensions shown are the minimum recommended dimensions (in mm) for providing adequate access around the boiler.

(using the top of the packaging case placed in front of the pallet head as an unloading ramp).

Note: for installations with several boilers in cascade, these same dimensions should be respected for each boiler.

C 330 ECO

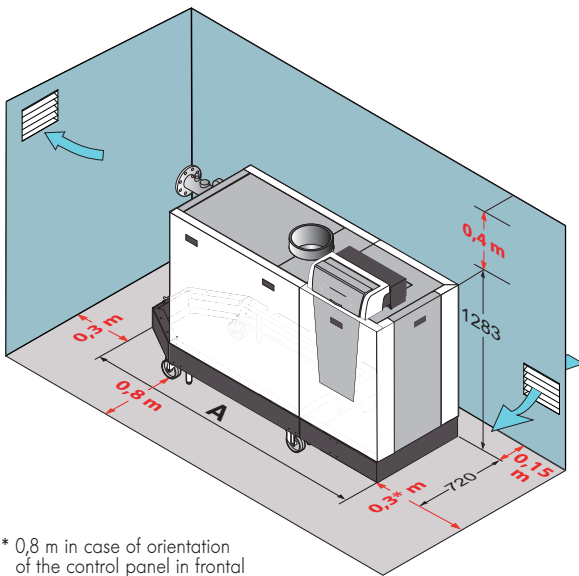

* 0,8 m in case of orientation of the control panel in frontal position

C330ECO_F0003A

C 630 ECO

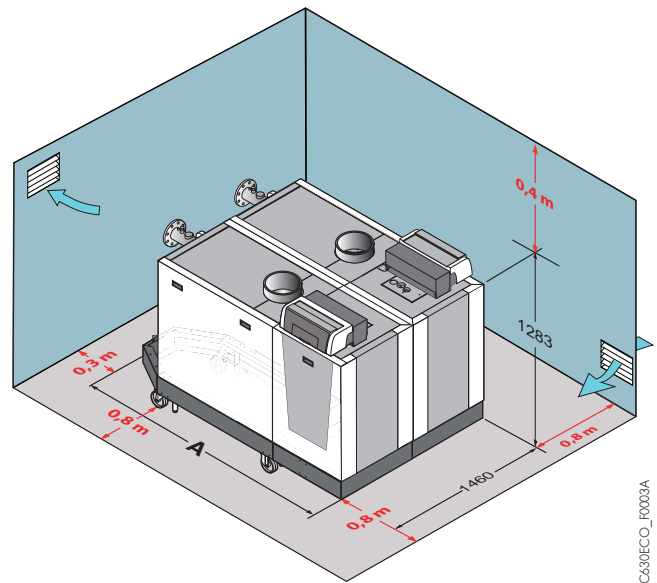

C630ECO_F0003A

	A (mm)
C 330-280 ECO	1862
C 330-350 ECO	1862
C 330-430 ECO	1862
C 330-500 ECO	2172
C 330-570 ECO	2172
C 330-650 ECO	2172

	A (mm)
C 630-560 ECO	1862
C 630-700 ECO	1862
C 630-860 ECO	1862
C 630-1000 ECO	2172
C 630-1140 ECO	2172
C 630-1300 ECO	2172

INFORMATION REQUIRED FOR INSTALLATION

As far as possible, the protective packaging around the boiler must only be removed once the boiler is in its definitive position. However, for practical transport reasons and for passage through doors and along corridors, it may be necessary to dismantle certain parts of the boiler.

The elements which can be dismantled are:

- the panels,
- the flue system and gas components,
- part of the base frame.

The diagram and control panel below give the dimensions of the largest piece transported (the base frame with the boiler body and hydraulic connections).

	L (mm)
C 330-280, C 330-350, C 330-430 C 630-560, C 630-700, C 630-860	1160
C 330-500, C 330-570, C 330-650 C 630-1000, C 630-1140, C 6130-1300	1469

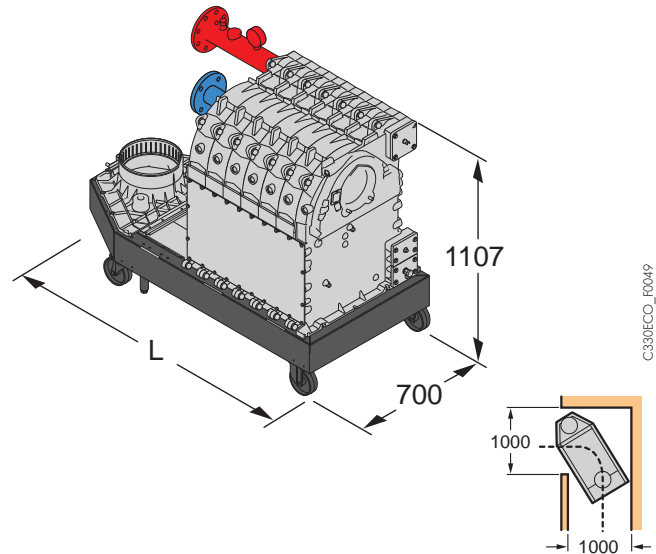

Boiler room ventilation

The cross-section of the boiler room ventilation (through which combustible air is taken in) must comply with the prevailing standard.



In order to avoid damage to boilers, it is necessary to prevent the contamination of combustion air by chloride and/or fluoride compounds, which are particularly corrosive. These compounds are present, for example, in aerosol spray cans, paints, solvents, cleaning products, washing powders/liquids, detergents, glues, snow clearing salts, etc.

It is therefore necessary:

- To avoid sucking in air discharged from premises using such products: hairdressers, dry cleaners, industrial premises (solvents), premises containing refrigeration systems (risk of leaking refrigeration fluid), etc.
- To avoid the storage of such products close to boilers.

Please note that, if the boiler and/or its peripherals become corroded by chloride and/or fluoride compounds, our contractual warranty cannot be invoked.

GAS CONNECTION

Compliance with prevailing instructions and regulations is mandatory. In all cases, a sectional valve is fitted as close as possible to the boiler. A filter should be fitted to the gas supply inlet immediately after the sectional valve.

The pipe diameters must be defined in accordance with prevailing specifications.

Gas storage bottles

Gas storage bottles are one of the solutions employed to correct the problem of the « min » or « max » pressure switches fitted to the gas burners being tripped unnecessarily.

This kind of tripping is related to the inertia of the gas regulator system, which causes partial vacuum and overpressures in the gas mains pipe when the burners start up or shut down.

Gas supply pressure:

- 20 mbar on natural gas H
- 25 mbar on natural gas L
- 300 mbar on natural gas H with pressure regulator, available as optional equipment

The volume calculation for a storage bottle can be performed using the software that we offer, in particular DIEMATOOLS, which is accessible on our Internet site, reserved for professionals.

INFORMATION REQUIRED FOR INSTALLATION

ELECTRICAL CONNECTION

This must comply with the prevailing standard.
The boiler is protected by a 4 A circuit breaker located behind the control panel. It must be powered by an electrical circuit comprising an omnipole switch with an opening distance > 3 mm.

HYDRAULIC CONNECTIONS

Important

The principle of a condensation boiler is to recycle the energy contained in the water vapour in the combustion gases (latent vaporisation heat). Consequently, to achieve an annual operating efficiency in the order of 109%, it is necessary to

Connection to the heating circuit

C 330/630-... ECO boilers must only be used in closed circuit heating installations. The central heating systems must be cleaned to eliminate the debris (copper, strands, brazing flux) linked to the installation of the system and deposits that can cause malfunctions (noise in the system, chemical reaction between metals). More particularly, if fitting a boiler to an existing installation, it is strongly recommended that you clear sludge

Requirements on heating water

Output of the installation kW	Total hardness TH °F
≤ 70	1 - 35
70 - 200	1 - 20
200 - 550	1 - 15
> 550	1 - 5

Water treatment

If the installation requires water treatment: consult us, particularly for:

- Water treatment which complies with the use of materials used in the construction of the boiler, the aluminium heating body, the pH of the water must not exceed 8.5.

Maximum/minimum water flow

The maximum difference in temperature between flow water and return water, and the speed at which the flow temperature increases, are restricted by the boiler's microprocessor ($\Delta T = 25^\circ\text{C}$); consequently, the boiler does not need a minimum flow rate provided that it operates at a maximum temperature of 75°C .

If the maximum temperature exceeds 75°C , it is necessary to respect the following minimum flow rates:

Minimum water flow rate

For the C 330-280 ECO	$Q_{\text{mini}} = 3.4 \text{ m}^3/\text{h}$
For the C 330-350 ECO	$Q_{\text{mini}} = 4.2 \text{ m}^3/\text{h}$
For the C 330-430 ECO	$Q_{\text{mini}} = 5.1 \text{ m}^3/\text{h}$
For the C 330-500 ECO	$Q_{\text{mini}} = 5.9 \text{ m}^3/\text{h}$
For the C 330-570 ECO	$Q_{\text{mini}} = 6.8 \text{ m}^3/\text{h}$

Condensates discharge

It must be connected to the waste water discharge system. The connection must be removable and the flow of condensates visible. The connections and pipes must be in corrosion-resistant material.

Notes:

- The sensor cables must be separated from the 230 V circuits by at least 10 cm.
- In order to protect the pump antifreeze and cleaning functions, we recommend not switching off the boiler at the mains switch.

size the heating surfaces in such a way as to obtain low return temperatures, below the dew point (e.g. underfloor heating, low temperature radiators, etc.) during the entire heating period.

out of the system before installing the new boiler. After carrying out this work, particular monitoring of the installation may be necessary both in respect of the water in the network and the quality of the water used for topping it up in order to be in full control of the consequences. Suitable filters may be necessary in some cases.

- Main pH: $\text{pH} < 8.5$
- Chloride: $< 50 \text{ mg/l}$

- The precautions to be taken to prevent the formation and localisation of oxygen in the water in the installation.
- Antifreeze products: ensure that these are compatible with aluminium and, if need be, with other components in the installation.

For the C 330-650 ECO	$Q_{\text{mini}} = 7.8 \text{ m}^3/\text{h}$
For the C 630 ECO, the minimum flow rate on each boiler will be equivalent to the minimum flow rate of a C 330 ECO	
For the C 630-560 ECO	$Q_{\text{mini}} = 6.8 \text{ m}^3/\text{h}$
For the C 630-700 ECO	$Q_{\text{mini}} = 8.4 \text{ m}^3/\text{h}$
For the C 630-860 ECO	$Q_{\text{mini}} = 10.2 \text{ m}^3/\text{h}$
For the C 630-1000 ECO	$Q_{\text{mini}} = 11.8 \text{ m}^3/\text{h}$
For the C 630-1140 ECO	$Q_{\text{mini}} = 13.6 \text{ m}^3/\text{h}$
For the C 630-1300 ECO	$Q_{\text{mini}} = 15.6 \text{ m}^3/\text{h}$

Maximum water flow rate

Flow speeds in the heating body which are too high reduce the transfer of heat. Therefore, it is necessary to restrict the water flow to the value obtained using the following formula:

$$Q_{\text{max}} (\text{m}^3/\text{h}) = \text{Nominal useful output} / 9.3$$

Condensates neutralisation stations are available as optional equipment. (see page 12).

EXAMPLES OF INSTALLATIONS

The examples presented below cannot cover the full range of installation scenarios which may be encountered. Their purpose is to draw the attention to the basic rules to be followed. A certain number of control and safety devices are represented but, in the last resort, it is up to the experts, consultant engineers and design departments to make the final decision on the control and safety devices to be used in the boiler room, depending on its specificities.

In all events, it is necessary to abide by the codes of practice and the local and national regulations in force.

NB: For the connection of domestic hot water, a sleeve made of steel, cast iron or any other insulating material must be interposed between the hot water outlet and this pipework to prevent any corrosion to the spot welds, if the distribution pipework is made of copper.

Installation of a C 330 ECO DIEMATIC iSystem with 1 underfloor heating circuit + 1 domestic hot water circuit

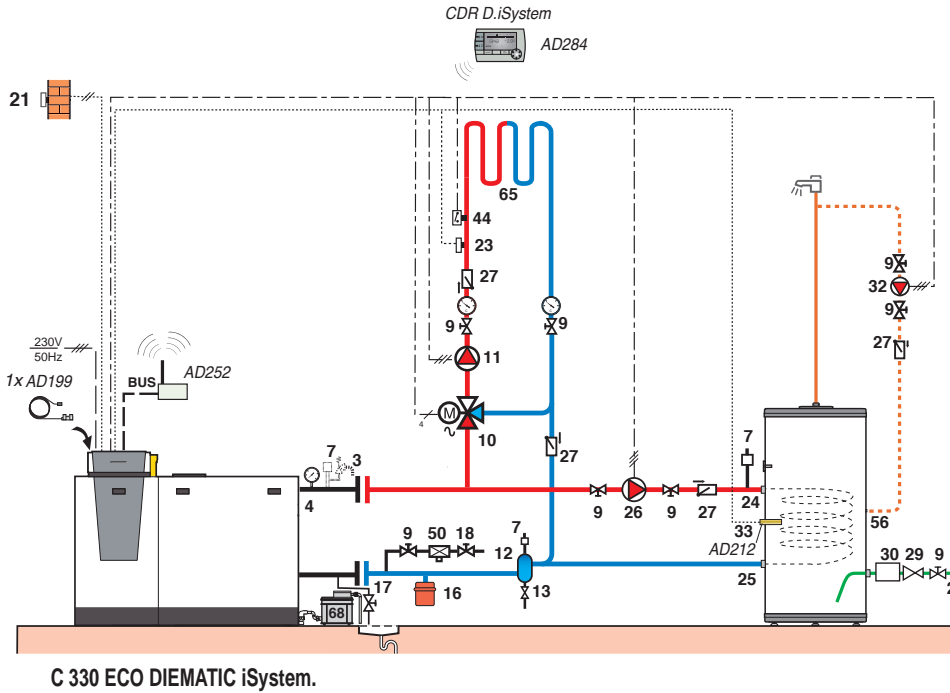

C330ECO_i00108

Installation of a C 330 ECO DIEMATIC iSystem with 1 "radiator" circuit + 1 circuit with mixing valve

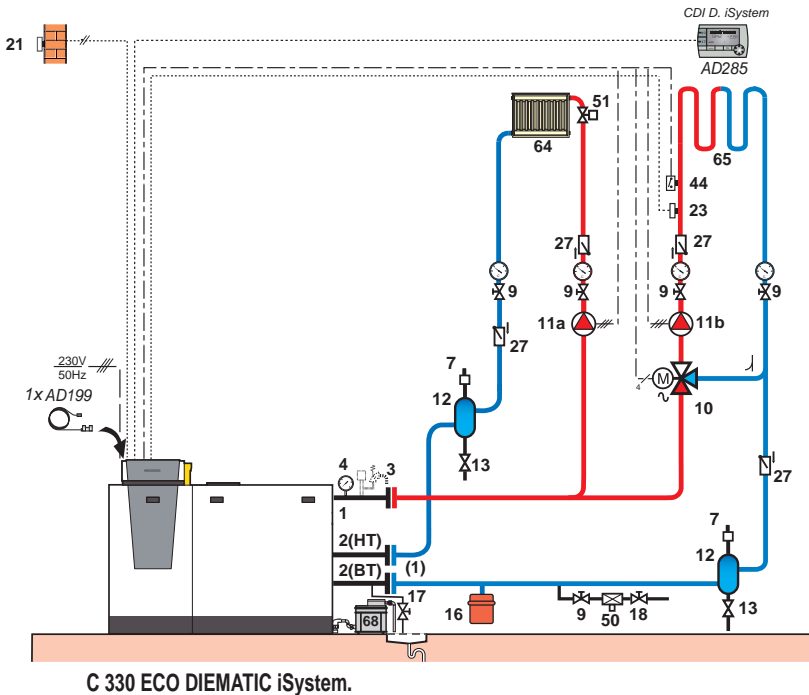

C330ECO_i0011C

(1) Flow rate distribution between the low temperature return (BT) and high temperature return (HT):

- Min. flow rate on BT and HT returns

$$= \frac{\text{Nominal flow rate}}{3}$$

and

- Min. flow rate on BT return

$$= \frac{3 \times \text{nominal flow rate}}{100}$$

(to ensure the irrigation of the return sensor)

Note: The return flow on HT can be = 0

Advantage: a performance gain of 4% max. can be achieved provided to ensure a flow rate on the BT return $\geq \frac{\text{Nominal flow}}{2}$

during the heating season.

Key: see p. 20

EXAMPLES OF INSTALLATIONS

Installation of 2 x C 330 ECO (DIEMATIC iSystem + IniControl) in cascade, with primary pump and decoupling cylinder, with 2 circuits with mixing valve + 1 domestic hot water circuit

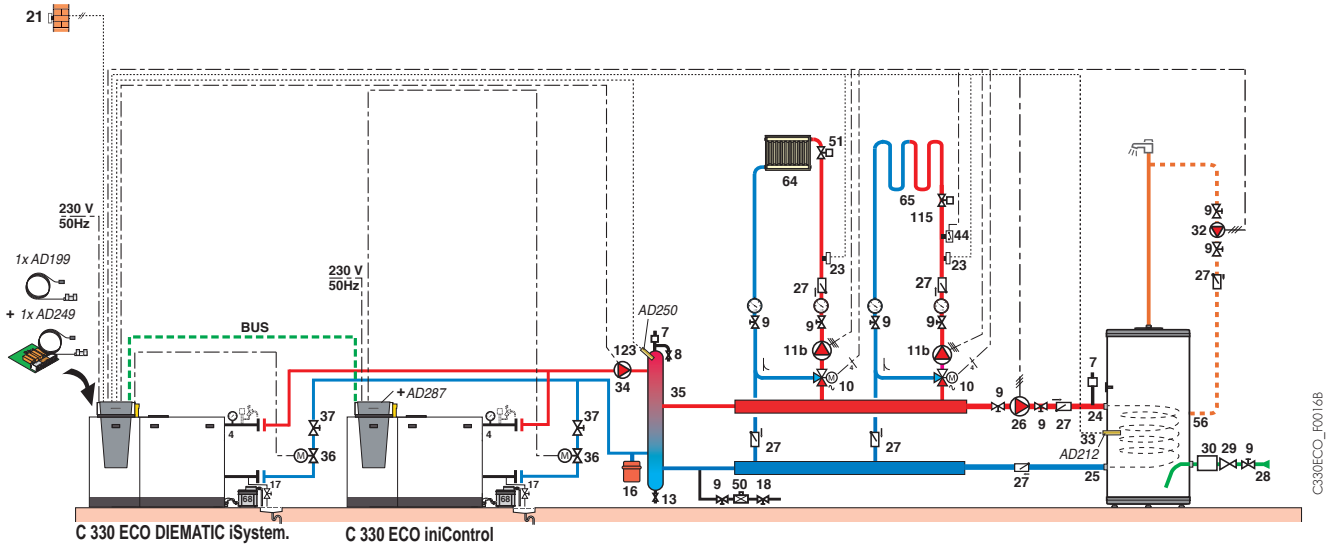

This diagram is only valid for 2 boilers maximum in cascade

Installation of 2 x C 330 ECO (DIEMATIC iSystem + IniControl) in cascade (type 1 primary circuit with injection pumps), with 2 circuits with mixing valve + 1 instant domestic hot water circuit with primary storage

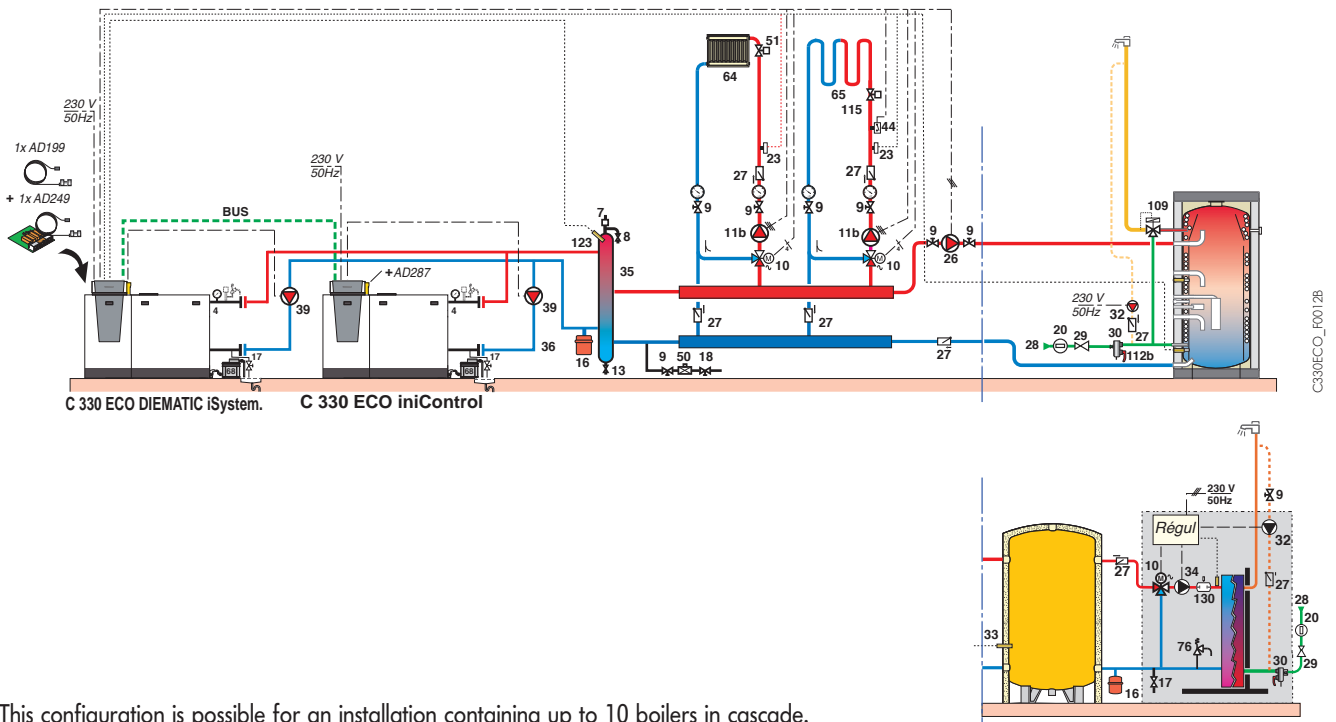

This configuration is possible for an installation containing up to 10 boilers in cascade.

Key: see p. 20

EXAMPLES OF INSTALLATIONS

Installation of a C 630 ECO DIEMATIC iSystem + IniControl with a direct underfloor heating circuit

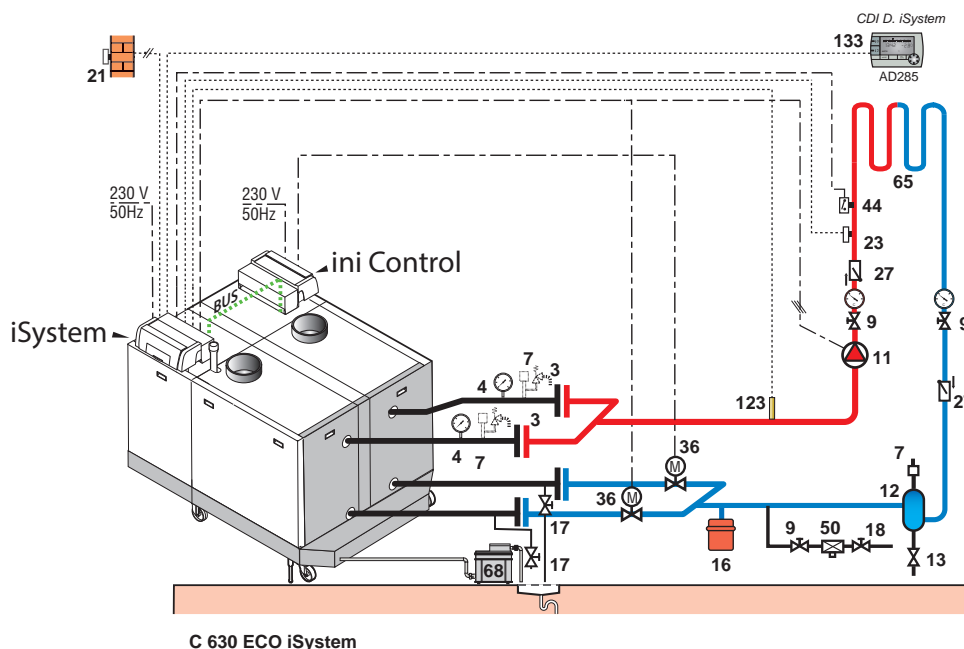

C330ECO_F0014C

Installation of a 2 x C 330/1 x C 630 ECO DIEMATIC iSystem with primary pump and decoupling cylinder, with 4 circuits with mixing valve + 1 solar domestic hot water circuit

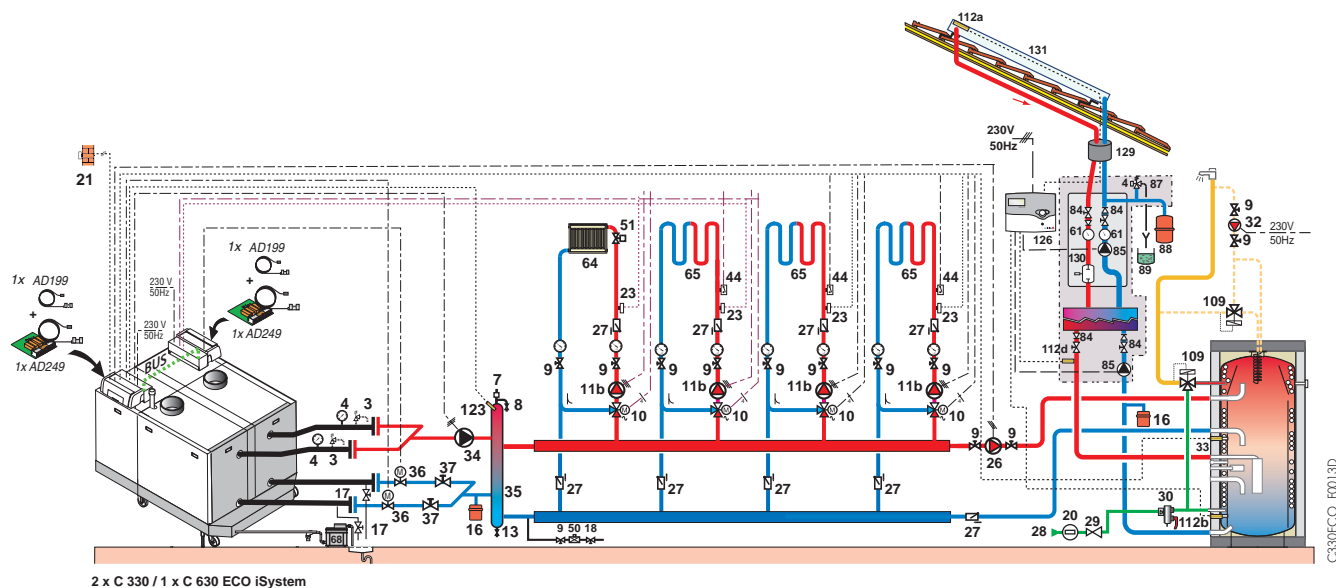

C330ECO_F0013D

Key

- | | | |
|--|--|--|
| <p>1 Heating flow
2 Heating return
3 Safety valve 3 bar (not delivered)
4 Pressure gauge (delivered)
7 Automatic air vent (not delivered)
8 Manual air vent
9 Valve
10 3-way mixing valve
11 Heating pump
13 Flush valve
16 Expansion vessel
17 Drainage valve
18 Heat circuit filling
21 Outside temperature sensor
22 Boiler control system sensor
23 Flow temp. sensor downstream of mixing valve</p> | <p>24 Primary inlet on the DHW tank exchanger
25 Primary outlet on the DHW tank exchanger
26 DHW load pump
27 Non-return valve
28 Domestic cold water inlet
29 Pressure reducer
30 Sealed safety unit calibrated to 7 bar
32 DHW loop pump (optional)
33 DHW temperature sensor
34 Primary pump
35 Decoupling tank
36 Motorised gate valve
39 Injection pump
44 Thermostat limiting the temperature to 65°C with manual reset for underfloor heating</p> | <p>50 Disconnector
51 Thermostatic valve
56 DHW circulation loop return
61 Thermometer
65 Low temperature circuit (radiator or underfloor heating)
68 Condensate neutralisation system (optional)
76 Diaphragm safety valve sealed and calibrated at 6 bar
115 Thermostatic distribution valve per zone
123 Cascade outlet sensor (to be connected to secondary boiler)
130 Degasser with manual vent (Airstop)
133 Interactive remote control</p> |
|--|--|--|

FLUE SYSTEMS

FLUE SYSTEMS

⇨ Configuration B_{23p}: connection to a chimney

Boiler type C 330-... ECO	Maximum air/flue gas pipe length (L _{max})(1)			
	Ø 150 mm	Ø 180 mm	Ø 200 mm	Ø 250 mm
280	20 m	50 m	50 m	50 m
350	11 m	30 m	50 m	50 m
430	8 m	22 m	39 m	50 m
500	7 m	18 m	32 m	50 m
570	5 m	13 m	24 m	50 m
650	5 m	12 m	21 m	50 m

x mini $\begin{matrix} \square & \text{(mm)} & D + 60 \\ \circ & \text{(mm)} & D + 80 \end{matrix}$

Boiler type C 630-... ECO	Maximum air/flue gas pipe length (L _{max})(1)		
	Ø 250 mm	Ø 300 mm	Ø 350 mm
560	50 m	50 m	50 m
700	31 m	50 m	50 m
860	20 m	50 m	50 m
1000	11 m	39 m	50 m
1140	5 m	26 m	50 m
1300	3 m	19 m	50 m

(1) Calculated for rigid pipes and outlet without flashing

⇨ Configuration B_{23p}: connection to a chimney, installation in cascade

	A (mm)
C 330-280, C 330-350, C 630-560, C 630-700	2100
C 330-430, C 330-500, C 330-570, C 330-650 C 630-860, C 630-1000, C 630-1140, C 630-1300	2490

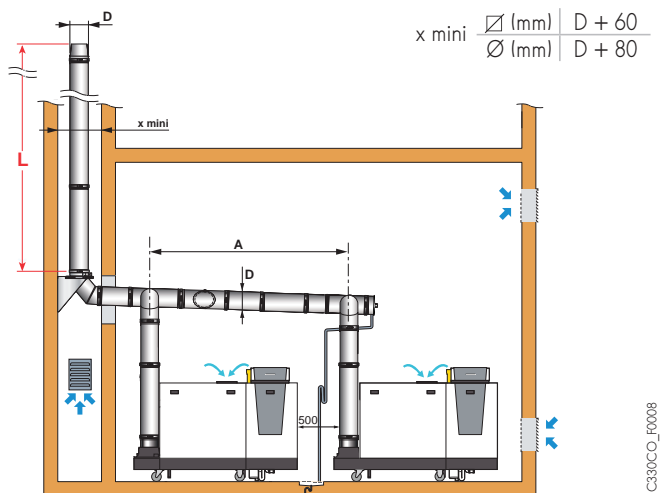
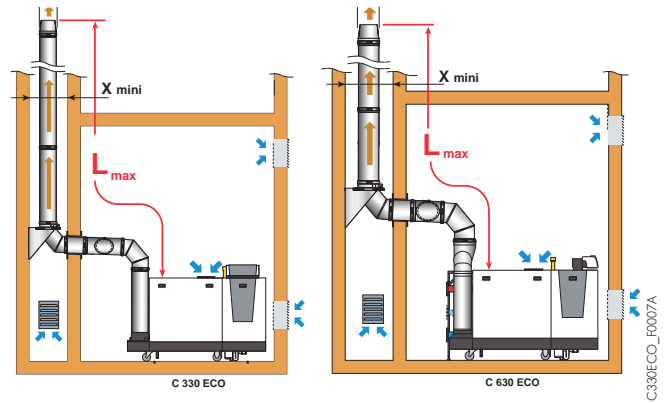

Maximum admissible length L (in m) depending on the Ø of the pipe D (in mm) for various "cascade" combinations (These lengths have been defined in accordance with the dimensional constraints given on the schematics above. For different dimensional constraints, consult us).

C 330-... ECO

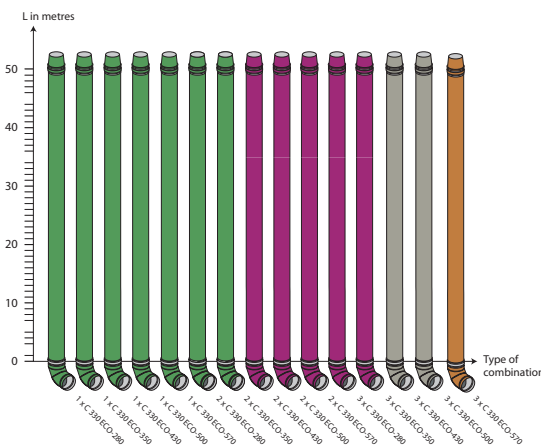

C 630-... ECO

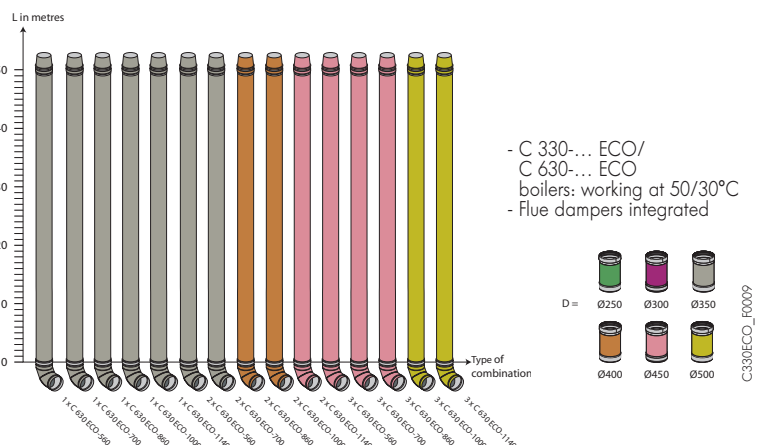

Note: These lengths are given as a rough guide. De Dietrich's liability may in no event be invoked. For different combinations, consult us.

FLUE SYSTEMS

⇒ Configuration C₃₃

Boiler type C 330-... ECO	Maximum air/flue gas pipe length (L _{max})(1)		
	Ø 200 mm	Ø 250 mm	Ø 300 mm
280	42 m	50 m	50 m
350	21 m	50 m	50 m
430	13 m	50 m <td 50 m	
500	10 m	50 m	50 m
570	5 m	34 m	50 m
650	4 m	50 m	50 m

Boiler type C 630-... ECO	Maximum air/flue gas pipe length (L _{max})(1)		
	Ø 300 mm	Ø 340 mm	Ø 400 mm
560	50 m	50 m	50 m
700	43 m	50 m	50 m
860	26 m	50 m	50 m
1000	13 m	35 m	50 m
1140	5 m	16 m	24 m
1300	-	10 m	12 m

Note: These maximum lengths are also applicable in configuration C₉₃.

(1) Calculated for rigid pipes and outlet without flashing

⇒ Configuration C₅₃

Boiler type C 330-... ECO	Maximum air/flue gas pipe length (L _{max})(1)	
	Ø 250 mm	
280	50 m	
350	50 m	
430	50 m	
500	50 m	
570	49 m	
650	40 m	

Boiler type C 630-... ECO	Maximum air/flue gas pipe length (L _{max})(1)	
	Ø 350 mm	Ø 400 mm
560	50 m	50 m
700	50 m	50 m
860	50 m	50 m
1000	33 m	50 m
1140	-	22 m
1300	-	-

(1) Calculated for rigid pipes and outlet without flashing

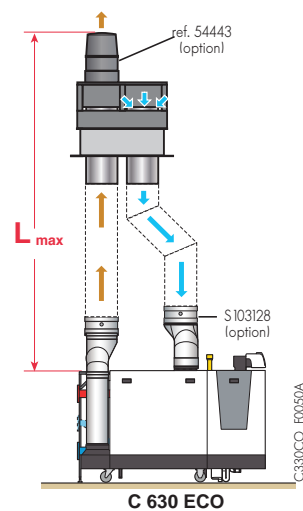
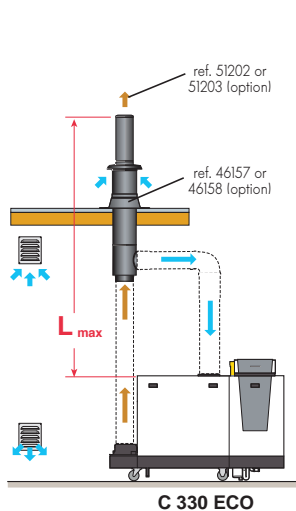

$$x \text{ mini } \begin{array}{l} \frac{\varnothing (\text{mm})}{\varnothing (\text{mm})} \mid \frac{D + 60}{D + 80} \end{array}$$

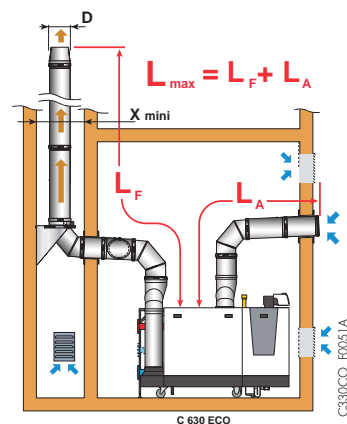
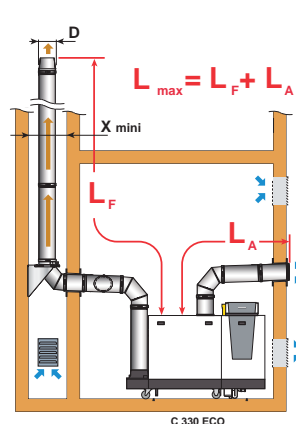

DESCRIPTION

C 330-... ECO

FLOOR STANDING GAS CONDENSING BOILERS

Brand: De Dietrich
Model: C 330-_____ ECO for heating only
CE identification No.: 0063CL3613
Useful output in heating mode at 50/30°C: _____ kW
Gas category: Natural gas
Max. working pressure: 7 bar
Water content: _____ Litre
Max. operating temperature: 90°C
Safety thermostat: 110°C
Gas pressure: 20/25 mbar

Gas flow: _____ m³/h
Flue gas pressure available at the nozzle: _____ Pa
Floor area: 716 (L) x _____ (I) mm
Gas inlet: 2"
Flue gas nozzle: Ø 250 mm
Combustive air inlet: Ø 250 mm
Heating/return flow nozzle: DN 80
Second return nozzle: DN 65
Condensates run-off: tube Ø 32 mm
Shipping weight: _____ kg

DESCRIPTION

- Complies with the requirements of European Directives
- Homologation: B₂₃ - B_{23p} - C₃₃ - C₅₃ - C₆₃ - C₈₃ - C₉₃
- Operating efficiency 109% PCI, efficiency class **** CE
- Exchanger in cast aluminium/silicium sections, with optimized exchanging surfaces, requiring no minimum temperature on the return and no minimum water flow (except when operating > 75°C)
- Cylindrical total remix gas burner in stainless steel with metallic fibres coating with emission of NO_x < 60mg/kWh (classification 5 according to EN 297 PrA2)
- Adaptation of boiler output to the needs of the installation, modulating from 20 to 100% in output
- Ignition and flame monitoring with ionisation sensor
- Integrated condensate receiver with 2 inspection hatches and a siphon
- Easy boiler positioning thanks to pivoting castors + rail guidance system
- Boiler can be delivered with 2 control panels:
 - **DIEMATIC iSystem** (on boiler alone): according to the outside temperature is able to control and regulate a direct circuit, 1 DHW circuit and (with options) up to 2 circuits with mixing valves (on master boiler): control a cascade up to 10 boilers equipped with IniControl control panels.
 - **IniControl**: for a boiler controlled through an extern 0 -10V signal, or for slave boilers in as cascade. The boilers are interconnected by a BUS connection cable and OpenTherm/ Modbus interfaces.
- Cascade up to 10 boilers

Boiler options

- 2nd return
- Tightness checker for gas train
- Minimum gas pressure switch
- Low water pressure switch
- Flue gas sensor
- Flue connection kit for 2 x C 330 ECO
- Air input collector for 2 x C 330 ECO
- 300 mbar pressure regulator
- Clearing knife
- Integral condensate neutralisation station (to be integrated under the casing)
- Recharge of granules for integral station
- Air intake filter
- 4 to 8 hole adapter flange for a pump

DIEMATIC iSystem control panel options

- PCB SCU-S05 for connecting external safety devices
- DIEMATIC VM iSystem wall-hung control unit
- PCB + sensor for 1 mixing valve
- Outlet sensor downstream of the valve
- DHW sensor
- Sensor for storage tank
- Room sensor
- Radio outside temperature sensor
- Boiler radio module
- CDI D. iSystem interactive remote control
- CDR D. iSystem interactive "radio" remote control
- Simplified remote control with room sensor
- BUS connection cable

IniControl panel options

- PCB SCU-S05 for connecting external safety devices
- OpenTherm Interface
- Outside sensor
- Programmable room thermostat (wireless)
- Programmable room thermostat (wire).

DESCRIPTION

C 630-... ECO

FLOOR STANDING GAS CONDENSING BOILERS

Brand: De Dietrich
Model: C 630-_____ ECO for heating only
CE identification No.: 0063CL3613
Useful output in heating mode at 50/30°C: _____ kW
Gas category: Natural gas
Max. working pressure: 7 bar
Water content: _____
Max. operating temperature: 90°C
Safety thermostat: 110°C
Gas pressure: 20/25 mbar

Gas flow: _____ m³/h
Flue gas pressure available at the nozzle: _____ Pa
Floor area: 1460 (L) x _____ (l) mm
Gas inlet: 2 x 2"
Flue gas nozzle: Ø 350 mm
Combustive air inlet: 2 x Ø 250 mm
Heating/return flow nozzle: 2 x DN 80
Second return nozzle: 2 x DN 65
Condensates run-off: 2 x tube Ø 32 mm
Shipping weight: _____ kg

DESCRIPTION

- Complies with the requirements of European Directives
- Homologation: B₂₃ - B_{23P} - C₃₃ - C₅₃ - C₆₃ - C₈₃ - C₉₃
- Operating efficiency 109% PCI, efficiency class **** CE
- Consists of 2 boilers (boiler + control panel) with common flue gas nozzle
- Exchanger in cast aluminium/silicium sections, with optimized exchanging surfaces, requiring no minimum temperature on the return and no minimum water flow (except when operating > 75°C)
- Cylindrical total remix gas burner in stainless steel with metallic fibres coating with emission of NO_x < 60mg/kWh (classification 5 according to EN 297 PrA2)
- Modulating from 15 to 100%
- Possibility to adapt the maximum boiler output to the needs of the installation, between 20 and 100 % from the nominal output of each boiler
- Ignition and flame monitoring with ionisation sensor
- Integrated condensate receiver with 2 inspection hatches and a siphon
- Easy boiler positioning thanks to pivoting castors + rail guidance system
- Cascade up to 5 boilers C 630-... ECO
- Boiler can be delivered in 3 version:

• DIEMATIC iSystem + IniControl control panels

According to the outside temperature this combination of control panels is able to control and regulate: a direct circuit, 1 DHW circuit and (with options) up to 2 circuits with mixing valves, the cascade of the 2 boilers of the unit (a BUS connecting cable and an OpenTherm/Modbus interface are delivered with the boiler), a cascade up to 5 boilers C 630- ECO equipped with IniControl or DIEMATIC iSystem control panels.

• 2 x DIEMATIC iSystem control panels

According to the outside temperature each control panel is able to control and regulate: a direct circuit, 1 DHW circuit and (with options) up to 2 circuits with mixing valves (for each control panel), a cascade up to 5 boilers C 630-... ECO. The control panels are interconnected by a BUS connection cable delivered with the boiler

• 2 x IniControl control panels

for a boiler controlled through an extern 0 -10V signal, or for slave boilers in as cascade. The slave boilers are interconnected by a BUS connection cable and OpenTherm/Modbus interfaces.

Boiler options

- 2nd return
- Tightness checker for gas train (x2)
- Minimum gas pressure switch (x2)
- Low water pressure switch
- Flue gas sensor
- Flue connection kit for 2 x C 330 ECO
- Air input collector for 2 x C 330 ECO
- 300 mbar pressure regulator
- Clearing knife
- Integral condensate neutralisation station (to be integrated under the casing, x2)
- Recharge of granules for integral station
- Air intake filter (x2)
- 4 to 8 hole adapter flange for a pump

DIEMATIC iSystem control panel options

- PCB SCU-S05 for connecting external safety devices
- DIEMATIC VM iSystem wall-hung control unit
- PCB + sensor for 1 mixing valve
- Outlet sensor downstream of the valve
- DHW sensor
- Sensor for storage tank
- Room sensor
- Radio outside temperature sensor
- Boiler radio module
- CDI D. iSystem interactive remote control
- CDR D. iSystem interactive "radio" remote control
- Simplified remote control with room sensor
- BUS connection cable

IniControl panel options

- PCB SCU-S05 for connecting external safety devices
- OpenTherm Interface
- Outside sensor
- Programmable room thermostat (wireless)
- Programmable room thermostat (wire).

DE DIETRICH THERMIQUE

S.A.S. with corporate capital of 22 487 610 €
57, rue de la Gare - F-67580 MERTZWILLER
Tel. +33 3 88 80 27 00 - Fax +33 3 88 80 27 99
www.dedietrich-heating.com